

FEATURES

- Ideally suited for automatic insertion
- For Switching and AF Amplifier Applications

SOT-23

1. BASE
2. EMITTER
3. COLLECTOR

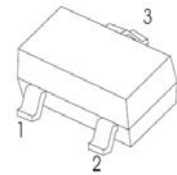

MAXIMUM RATINGS (T_a=25°C unless otherwise noted)

| Symbol | Parameter | Value | Unit |
|------------------------|---|----------|------|
| V_{CB0} | Collector-Base Voltage | | V |
| | BC846 | 80 | |
| | BC847 | 50 | |
| | BC848 | 30 | |
| V_{CEO} | Collector-Emitter Voltage | | V |
| | BC846 | 65 | |
| | BC847 | 45 | |
| | BC848 | 30 | |
| V_{EBO} | Emitter-Base Voltage | 6 | V |
| I_C | Collector Current –Continuous | 0.1 | A |
| P_C | Collector Power Dissipation | 200 | mW |
| R_{θJA} | Thermal Resistance From Junction To Ambient | 625 | °C/W |
| T_J | Junction Temperature | 150 | °C |
| T_{stg} | Storage Temperature | -55~+150 | °C |

ELECTRICAL CHARACTERISTICS (T_a=25°C unless otherwise specified)

| Parameter | Symbol | Test conditions | Min | Typ | Max | Unit | |
|--------------------------------------|------------------|---|-------------------------|-----|-----|---------|--|
| Collector-base breakdown voltage | BC846 | $I_C = 10\mu A, I_E = 0$ | 80 | | | V | |
| | BC847 | | 50 | | | | |
| | BC848 | | 30 | | | | |
| Collector-emitter breakdown voltage | BC846 | $I_C = 10mA, I_B = 0$ | 65 | | | V | |
| | BC847 | | 45 | | | | |
| | BC848 | | 30 | | | | |
| Emitter-base breakdown voltage | V_{EBO} | $I_E = 10\mu A, I_C = 0$ | 6 | | | V | |
| Collector cut-off current | BC846 | $V_{CB} = 70V, I_E = 0$ | | | 0.1 | μA | |
| | BC847 | | $V_{CB} = 50V, I_E = 0$ | | | | |
| | BC848 | | $V_{CB} = 30V, I_E = 0$ | | | | |
| Collector cut-off current | BC846 | $V_{CE} = 60V, I_B = 0$ | | | 0.1 | μA | |
| | BC847 | | $V_{CE} = 45V, I_B = 0$ | | | | |
| | BC848 | | $V_{CE} = 30V, I_B = 0$ | | | | |
| Emitter cut-off current | I_{EBO} | $V_{EB} = 5V, I_C = 0$ | | | 0.1 | μA | |
| DC current gain | BC846A,847A,848A | $V_{CE} = 5V, I_C = 2mA$ | 110 | | 220 | | |
| | BC846B,847B,848B | | 200 | | 450 | | |
| | BC847C,BC848C | | 420 | | 800 | | |
| Collector-emitter saturation voltage | $V_{CE(sat)}$ | $I_C = 100mA, I_B = 5mA$ | | | 0.5 | V | |
| Base-emitter saturation voltage | $V_{BE(sat)}$ | $I_C = 100mA, I_B = 5mA$ | | | 1.1 | V | |
| Transition frequency | f_T | $V_{CE} = 5V, I_C = 10mA$ $f = 100MHz$ | 100 | | | MHz | |
| Collector output capacitance | C_{ob} | $V_{CB} = 10V, f = 1MHz$ | | | 4.5 | pF | |

RATING AND CHARACTERISTICS CURVES (BC846 THRU BC848)

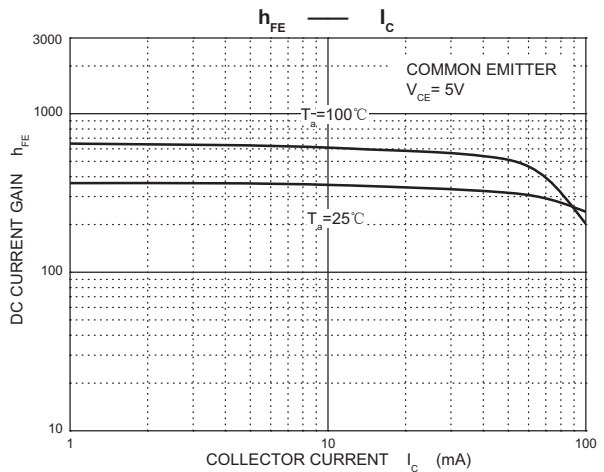
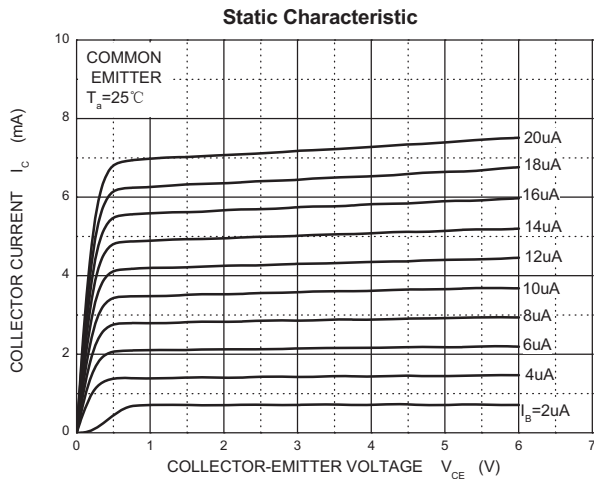

RATING AND CHARACTERISTICS CURVES (BC846 THRU BC848)

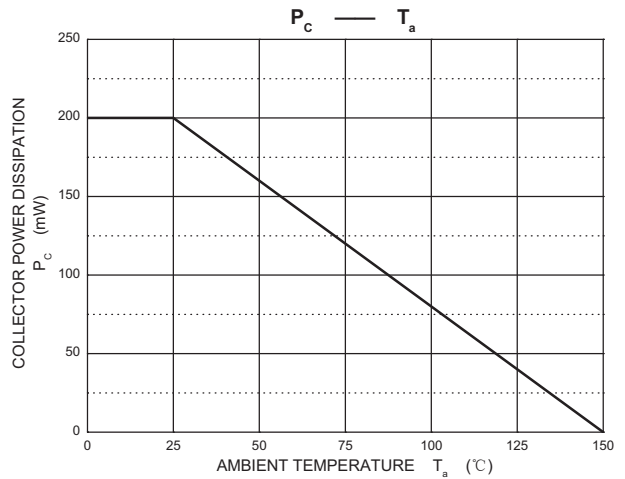
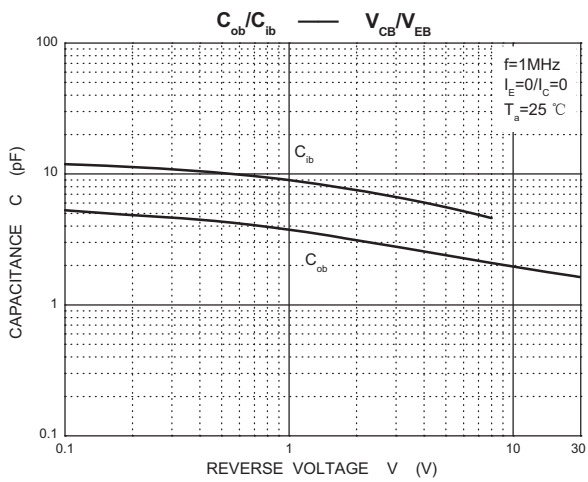
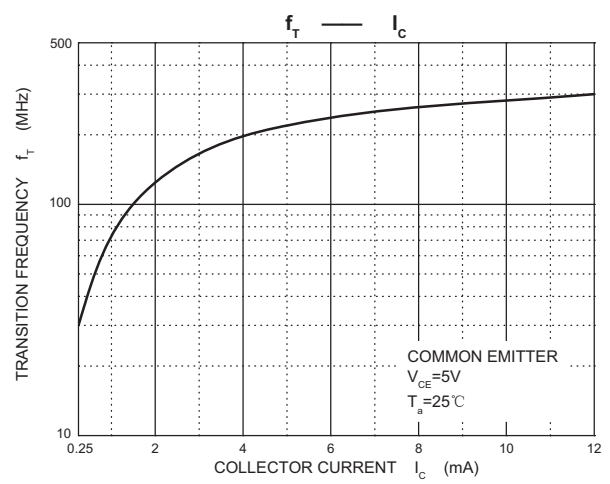
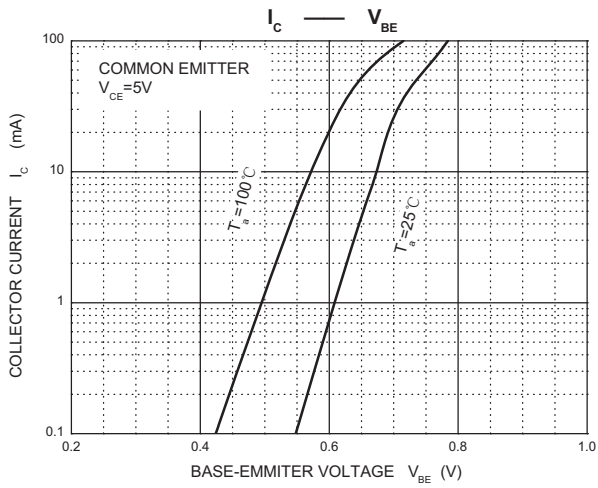
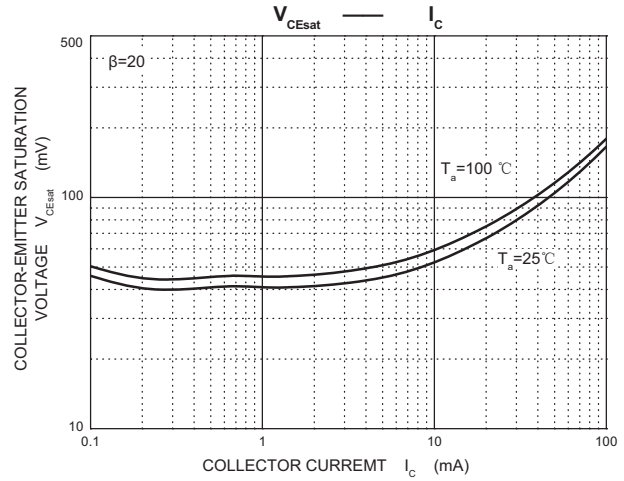
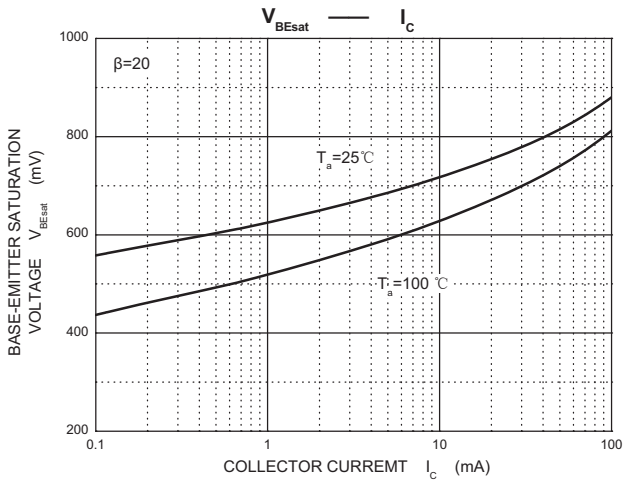

SOT-23 Package Outline Dimensions

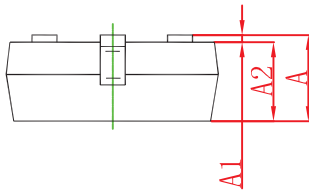
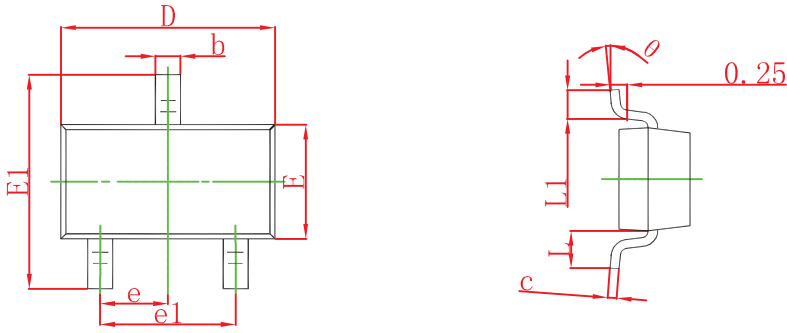

| Symbol | Dimensions In Millimeters | | Dimensions In Inches | |
|--------|---------------------------|-------|----------------------|-------|
| | Min | Max | Min | Max |
| A | 0.900 | 1.150 | 0.035 | 0.045 |
| A1 | 0.000 | 0.100 | 0.000 | 0.004 |
| A2 | 0.900 | 1.050 | 0.035 | 0.041 |
| b | 0.300 | 0.500 | 0.012 | 0.020 |
| c | 0.080 | 0.150 | 0.003 | 0.006 |
| D | 2.800 | 3.000 | 0.110 | 0.118 |
| E | 1.200 | 1.400 | 0.047 | 0.055 |
| E1 | 2.250 | 2.550 | 0.089 | 0.100 |
| e | 0.950 TYP | | 0.037 TYP | |
| e1 | 1.800 | 2.000 | 0.071 | 0.079 |
| L | 0.550 REF | | 0.022 REF | |
| L1 | 0.300 | 0.500 | 0.012 | 0.020 |
| theta | 0° | 8° | 0° | 8° |

SOT-23 Suggested Pad Layout

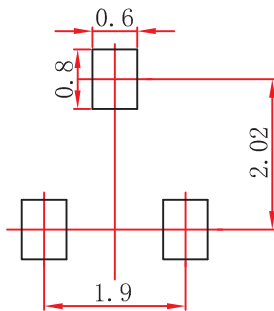

Note:

1. Controlling dimension: in millimeters.
2. General tolerance: $\pm 0.05\text{mm}$.
3. The pad layout is for reference purposes only.

DEVICE MARKING

BC846=1D; BC846A=1A; BC846B=1B;
 BC847=1H; BC847A=1E; BC847B=1F; BC847C=1G;
 BC848A=1J; BC848B=1K; BC848C=1L

SOT-23 Tape and Reel

SOT-23 Embossed Carrier Tape

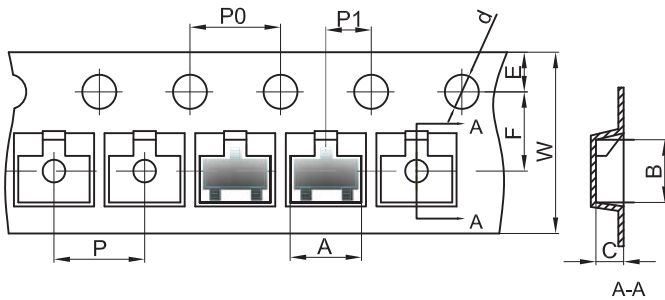

Packaging Description:

SOT-23 parts are shipped in tape. The carrier tape is made from a dissipative (carbon filled) polycarbonate resin. The cover tape is a multilayer film (Heat Activated Adhesive in nature) primarily composed of polyester film, adhesive layer, sealant, and anti-static sprayed agent. These reeled parts in standard option are shipped with 3,000 units per 7" or 17.8cm diameter reel. The reels are clear in color and is made of polystyrene plastic (anti-static coated).

Dimensions are in millimeter

| Pkg type | A | B | C | d | E | F | P0 | P | P1 | W |
|----------|------|------|------|-------|------|------|------|------|------|------|
| SOT-23 | 3.15 | 2.77 | 1.22 | Ø1.50 | 1.75 | 3.50 | 4.00 | 4.00 | 2.00 | 8.00 |

SOT-23 Tape Leader and Trailer

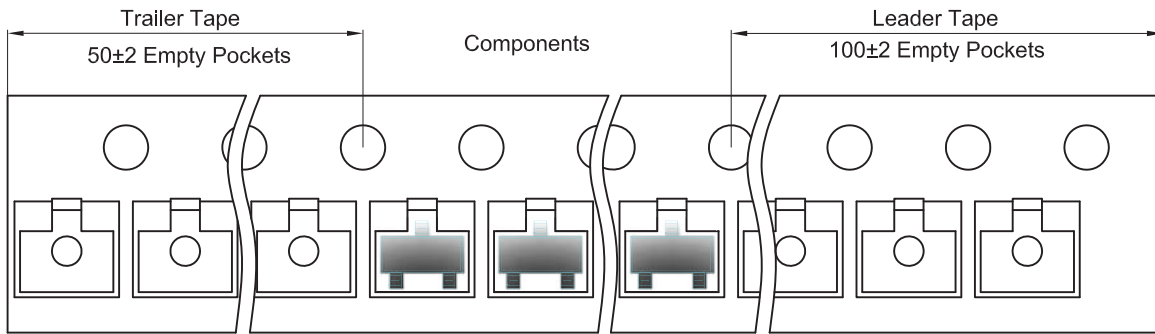

SOT-23 Reel

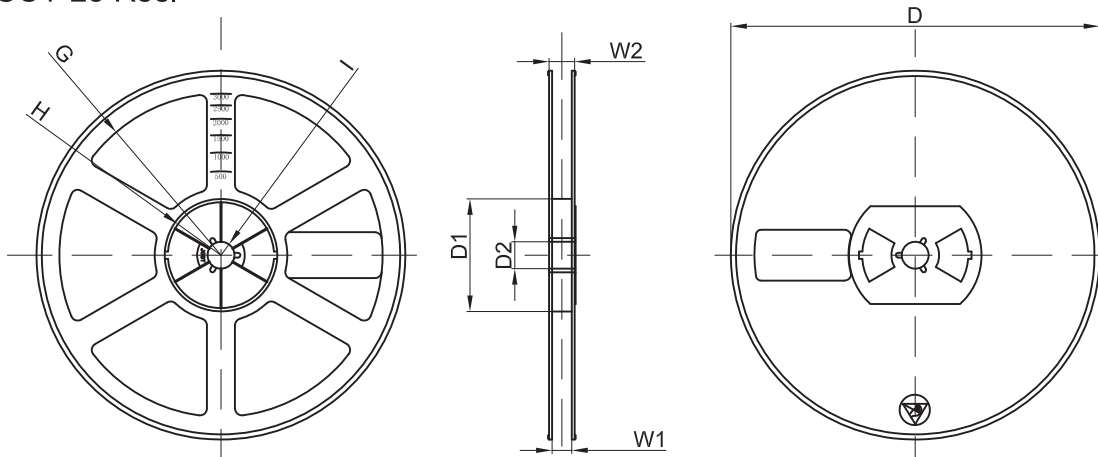

Dimensions are in millimeter

| Reel Option | D | D1 | D2 | G | H | I | W1 | W2 |
|-------------|---------|-------|-------|--------|--------|-------|------|-------|
| 7" Dia | Ø178.00 | 54.40 | 13.00 | R78.00 | R25.60 | R6.50 | 9.50 | 12.30 |

| REEL | Reel Size | Box | Box Size(mm) | Carton | Carton Size(mm) | G.W.(kg) |
|----------|-----------|------------|--------------|-------------|-----------------|----------|
| 3000 pcs | 7 inch | 45,000 pcs | 203×203×195 | 180,000 pcs | 438×438×220 | |

DISCLAIMER NOTICE

Rectron Inc reserves the right to make changes without notice to any product specification herein, to make corrections, modifications, enhancements or other changes. Rectron Inc or anyone on its behalf assumes no responsibility or liability for any errors or inaccuracies. Data sheet specifications and its information contained are intended to provide a product description only. "Typical" parameters which may be included on RECTRON data sheets and/ or specifications can and do vary in different applications and actual performance may vary over time. Rectron Inc does not assume any liability arising out of the application or use of any product or circuit.

Rectron products are not designed, intended or authorized for use in medical, life-saving implant or other applications intended for life-sustaining or other related applications where a failure or malfunction of component or circuitry may directly or indirectly cause injury or threaten a life without expressed written approval of Rectron Inc. Customers using or selling Rectron components for use in such applications do so at their own risk and shall agree to fully indemnify Rectron Inc and its subsidiaries harmless against all claims, damages and expenditures.